

# BRITISH STANDARD PIPE TAPER THREADS (BSPT<sub>r</sub>)

Application : Used for fastening of pipe threads where, pressure tight joints are required on threads.

**SPECIFICATION :**  
BS Standard: BS 21-1985.

Indian Standard: \* Basic Dimensions: IS 554-1975,  
\* Gauging Practice: IS 8999 - 1979

\* These specifications are replaced first by ISO 7/2-1984 & later on by ISO 7/2-2000. As these gauges are still used in industry, we manufacture these based on specific customer request.

## BSPT<sub>r</sub> THREAD PROFILE

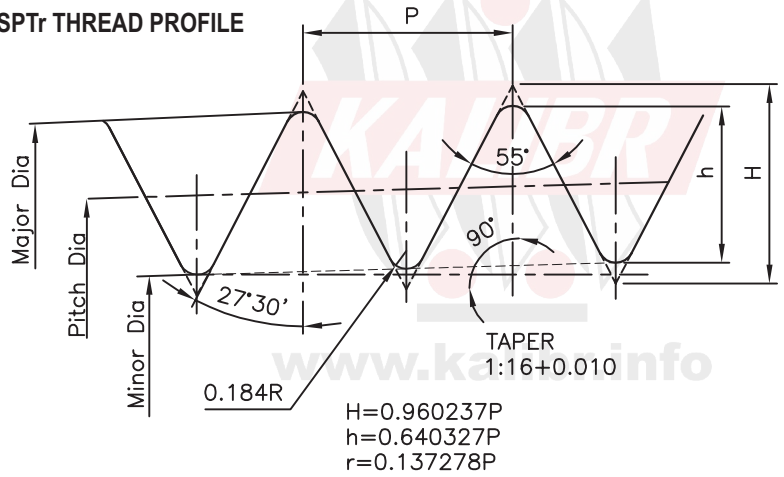

## MANUFACTURING RANGE.

| Diameter (Inch)                       | TPI | Type of Gauges        |                     |                               |  |
|---------------------------------------|-----|-----------------------|---------------------|-------------------------------|--|
| 1/16, & 1/8                           | 28  | Thread Plug Gauges    | Thread Ring Gauges  | Check Plug to check NEW Rings | Wear Check Plug Gauges to check/ calibrate used Rings. |
| 1/4 & 3/8                             | 19  | System A. & System B. | System A & System B | System A & System B           | System A & System B                                    |
| 1/2 & 3/4                             | 14  |                       |                     |                               |  |
| 1, 1.1/4, 1.1/2, 2, 2.1/2, 3, 4, 5, 6 | 11  |                       |                     |                               |  |

Specification recommends,  
**To check Internal Taper Threads -**  
Taper Thread Plug either System 'A' OR System 'B'

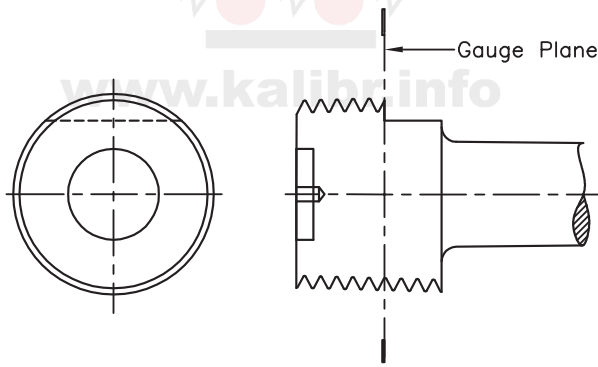

BSPT<sub>r</sub> System A Plug

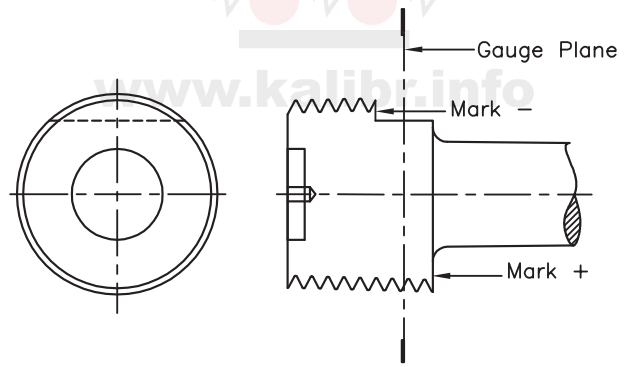

BSPT<sub>r</sub> System B Plug

To check external Taper Threads.  
Taper Ring Gauges either System 'A' OR System 'B'

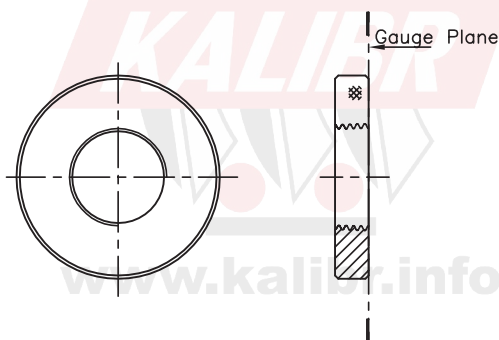

BSPT<sub>r</sub> System A Ring

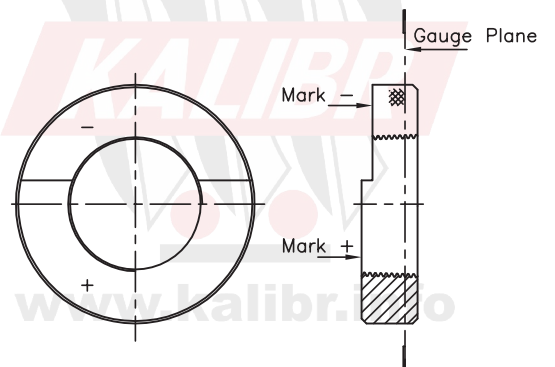

BSPT<sub>r</sub> System B Ring